

**PHT**

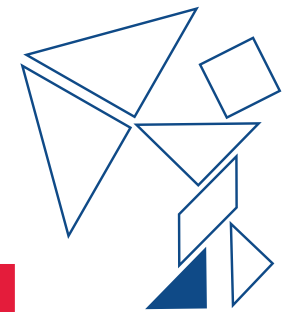

**H**igiene

[www.pht.group](http://www.pht.group)

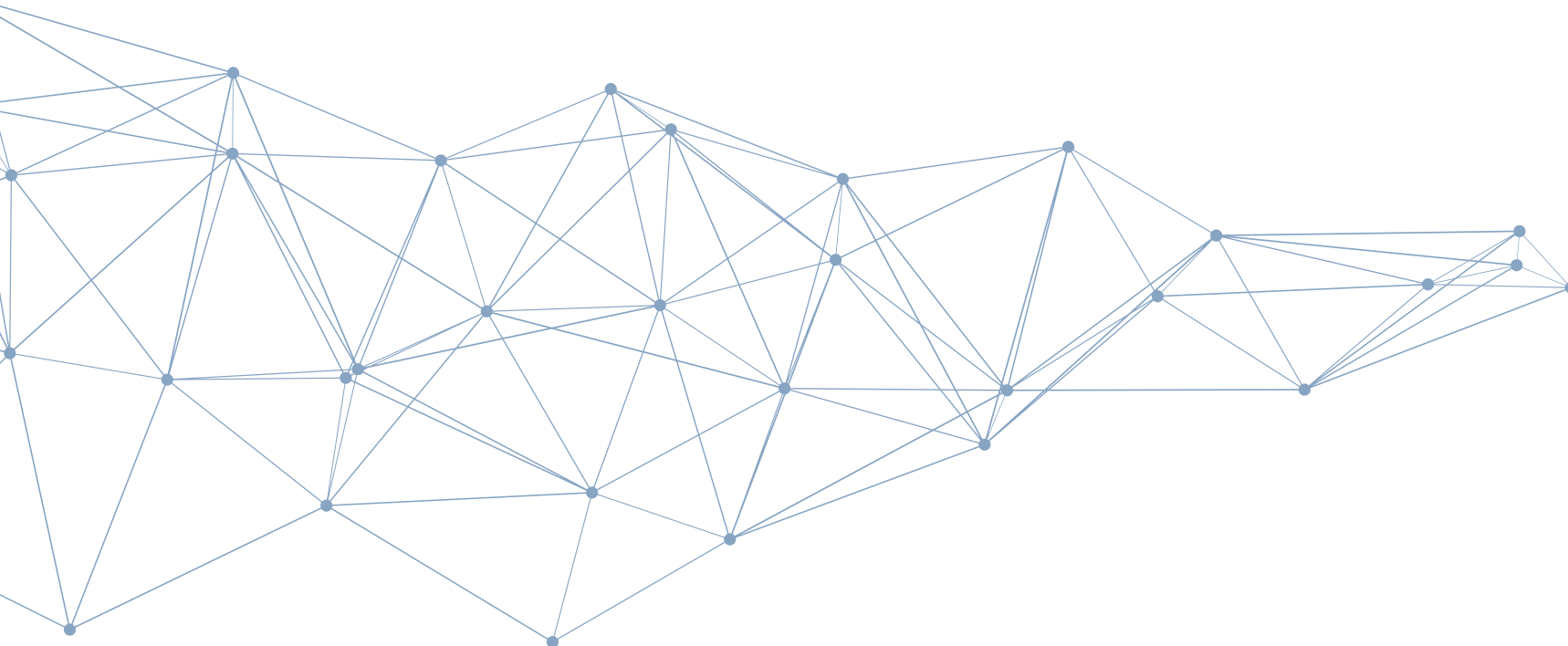

# PHT stands for Partnership, Hygiene and Technology

To help you find your way around the PHT world, we have organized our portfolio according to three business units:

## Partnership

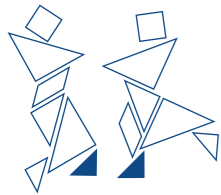

### Service

From conceptualization, detailed technical planning to total hygiene packages

### After-Sales-Service

From delivery and installation, training and commissioning, as well as start-up, up to maintenance and a service contracts

## Hygiene



### Employee hygiene

We cover all hygiene-relevant points in your workflow starting with access control, from change rooms and canteens to hygiene lobbies and all necessary hygiene equipment for your facility.

### Facility hygiene

Everything you need for cleaning your facility and machines: From high-quality brush ware to low-pressure foam cleaning technology, coupled with all the required accessories for drainage systems, and complete furnishing of your chemicals room.

## Technology

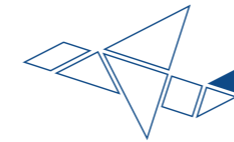

### Cleaning and drainage technology

We offer innovative cleaning and drying technology for all tubs, containers, trolleys and transfer systems in your facility. And because thinking about hygiene does not end at the wastewater outlet of a machine, we also offer appropriate drainage technology.

### Handling and logistics systems

From the design and installation of high-quality, hygienic stainless steel equipment to automated lifting and tilting systems and technology for conveyor, racking and commissioning systems. Modern systems protect your products and reduce the time spent on the production floor, and so promote hygiene.

We further design customized hygienic slaughtering, deboning and cutting as well as smoking and cooking systems. Modern systems, for example UV and Microwave technology, protect your products, shorten the time required for manual input and thereby increase the overall hygiene.



# PHT products in Facility Hygiene

Sole and wheel cleaning  
Hygienic Floor System

Foam cleaning  
Mainstation

Mobile trolley for  
satellite, hose and chemistry

Shadow board

Multi-booster

Dosing station for  
pre-dissolved chemistry

Chemistry bulk

Chemical transfer system  
from large to small bulks

Satellite SU 0127 Baseline

Nozzle holder

Automatic system  
for programmable  
foam cleaning

Hose reel

Satellite SU 0127

Lockable canister holder

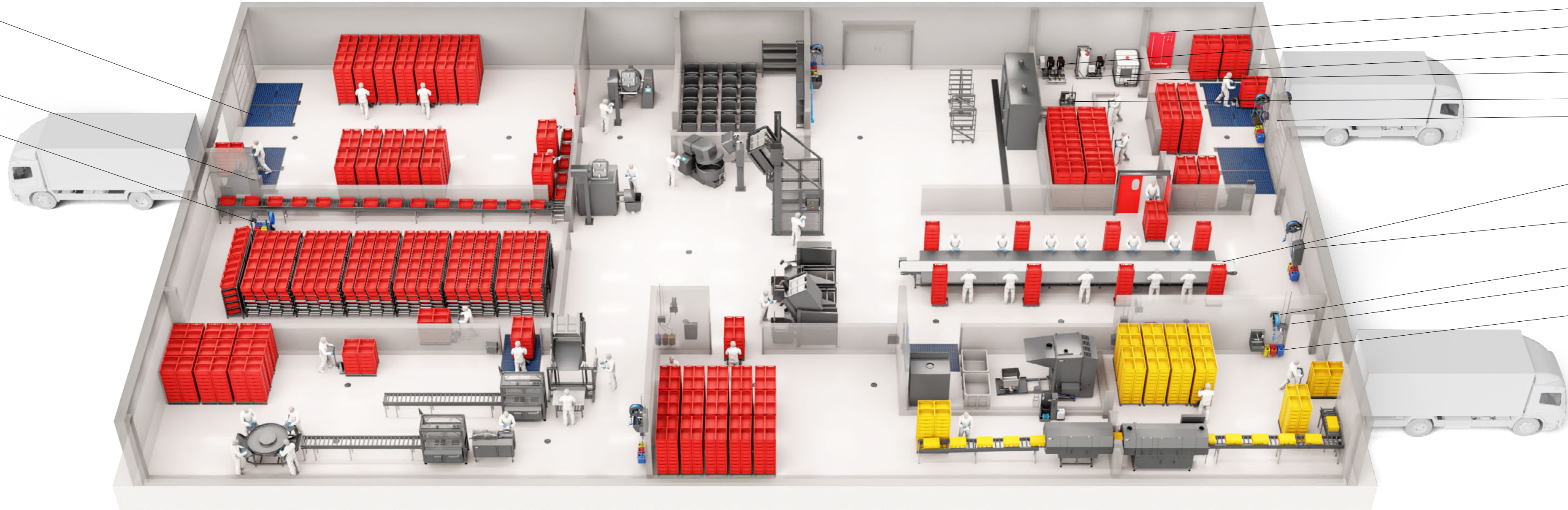

# Hygienic production with innovative cleaning systems

## Facility Hygiene

The right facility hygiene is a decisive factor in a functioning overall hygiene concept. PHT develops well thought-out concepts for industrial hygiene for the food industry and companies with hygiene-sensitive areas, in which all components are interlinked. This begins with the innovative low-pressure foam cleaning system and extends to the professional cleaning requirements according to the colour system, which offer the highest level of hygiene and also maximum occupational safety.



Image 63

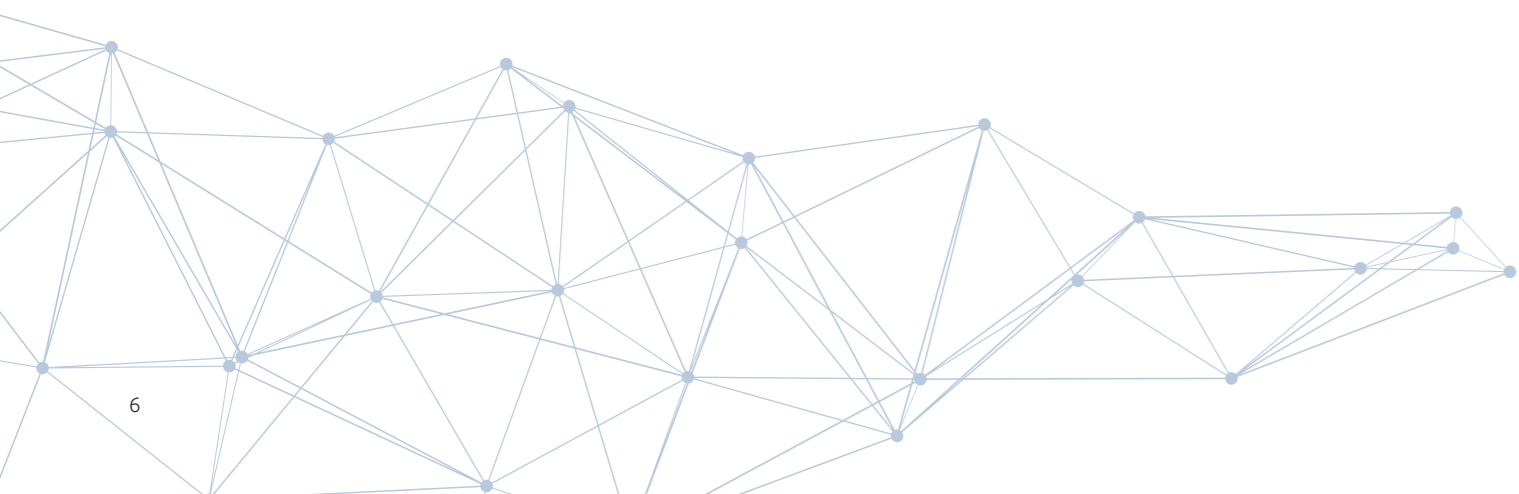



Image 64

# Low-pressure foam cleaning

Mainstation for the production.



Image 65 Mainstation MS 0427-4 Next



Image 66 Hose reel AV3500



Image 67 Satellite SU 0127-4 Next



Image 68 Canister holder for three canisters



Image 69 Lockable Canister holder for three canisters



Image 70



Image 71 Cleaning pistol PHT 12-100



Image 72 Hose reel AV3500



Image 73 Satellite SU 0127-4 Next



Image 74 Booster



Image 75 Canister holder for three canisters

# Low-pressure foam cleaning

Pumps outside production.



Image 76

# Cleaning systems as needed

Adapted solutions.



Image 77 Satellite SU 0127 Baseline



Image 78 Hose reel AV3500



Image 79 Satellite SU 0110 TWP  
light for house water supply



Image 80 Canister holder for two canisters



Image 81

# Cleaning with pre-dissolved chemistry

Central chemical supply.



Image 82 Hose reel AV3500



Image 83 Satellite PSU 0127-4 Next with additional injector



Image 84 Satellite PSU 0127-4 Next



Image 85 Multi-Booster



Image 86 Dosing station for pre-dissolved chemistry



Image 87 Chemistry bulk



Image 88 Chemical transfer system from large to small bulks



Image 89



# Mobile foam cleaning

Anytime and anywhere.



Image 90 Mobile foam cleaning system MOC 0127



Image 91 Mobile trolley for satellite, hose and chemistry

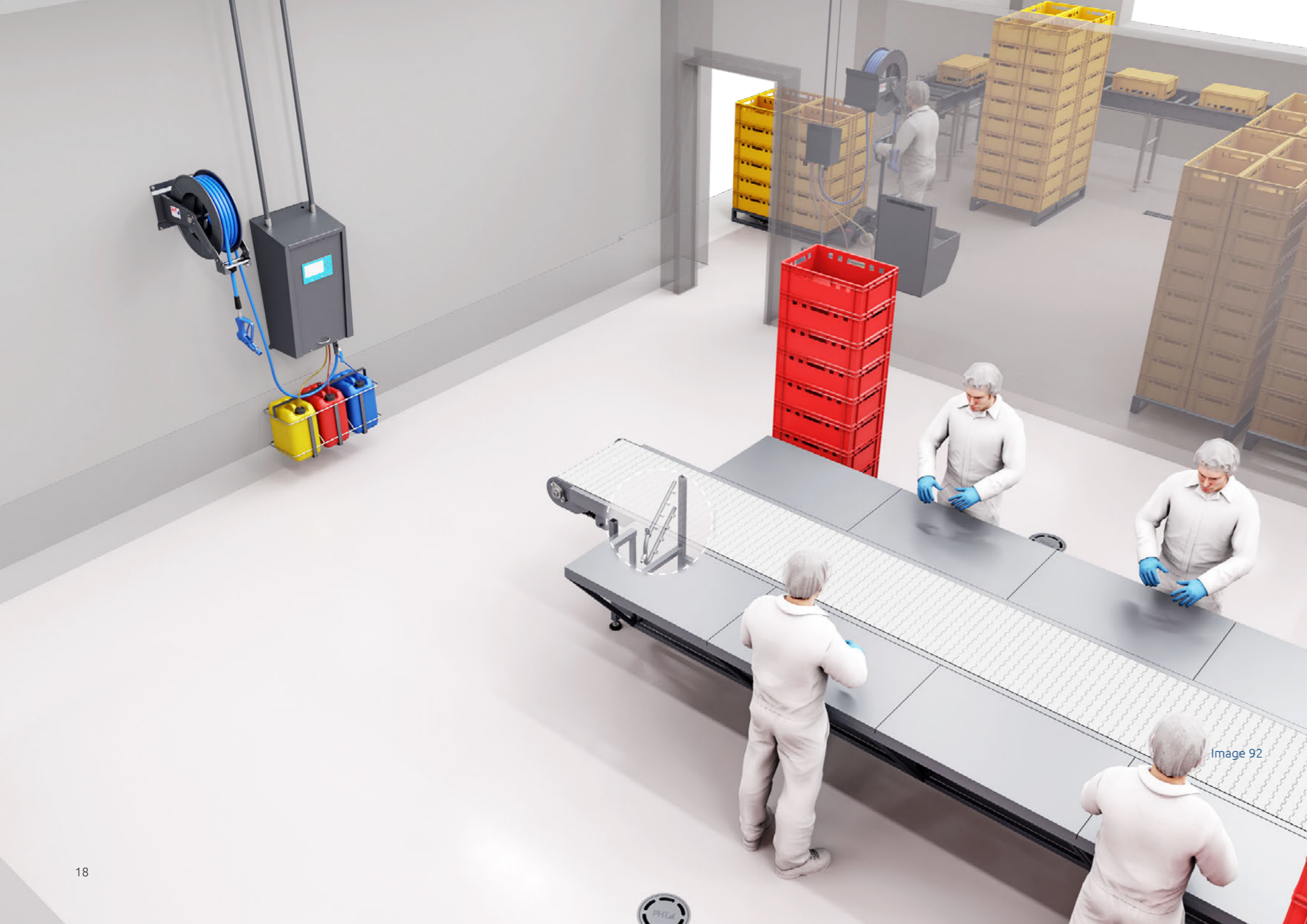

Image 92

# Automatic cleaning

Programmable cleaning processes.



Image 93 Automatic system



Image 94 Automatic system, opened



Image 95 Canister holder for three canisters

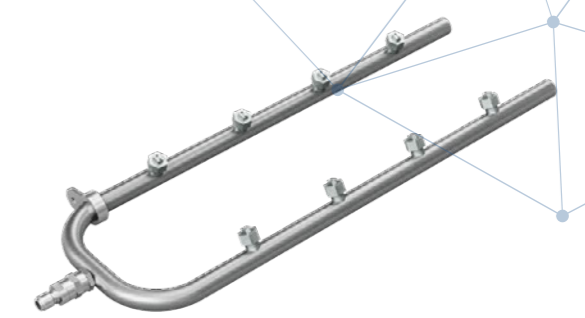

Image 96 Nozzle holder

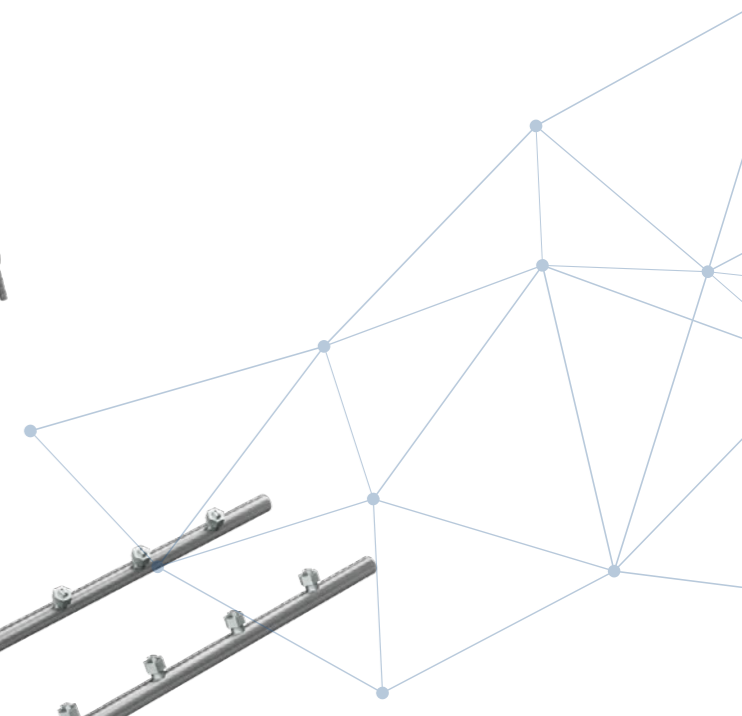



Image 97

# Material sluice

Sole and wheel cleaning.

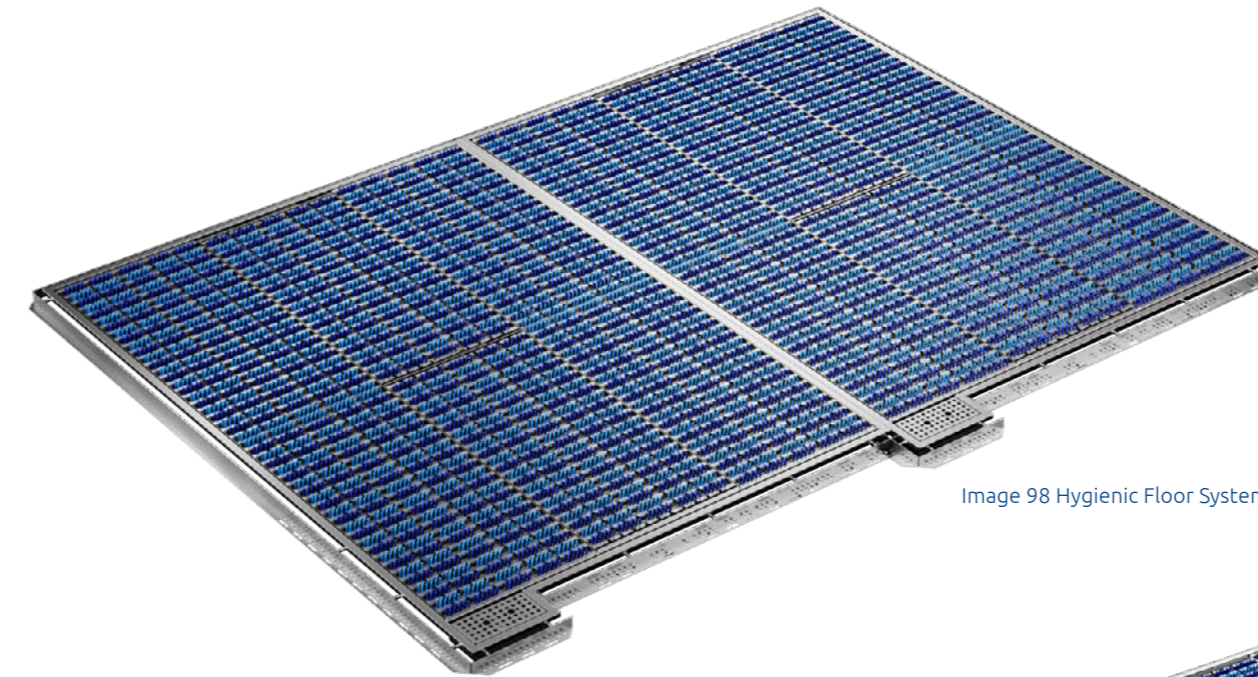

Image 98 Hygienic Floor System



Image 99 Dosing station

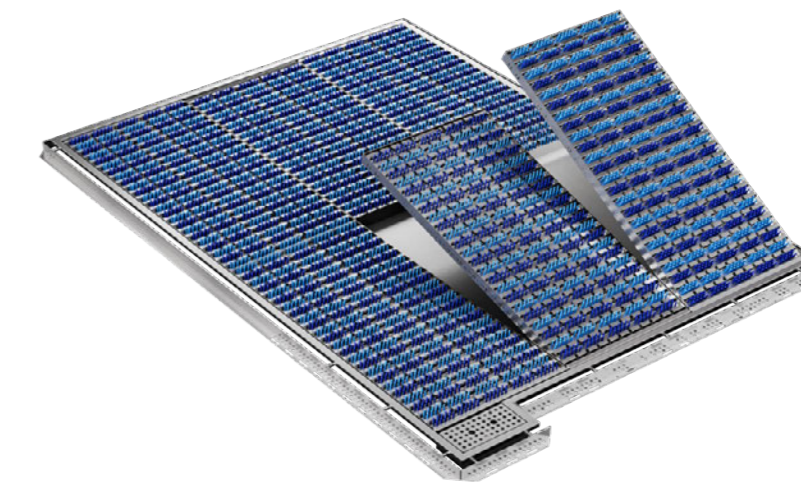

Image 100 Hygienic Floor System with open cassettes



Image 101



Image 102 Hand brush



Image 103 Scraper



Image 104 Dustpan



Image 105 Hand shovel



Image 106 Universal brush



Image 107 Bucket



Image 108 Broom with handle



Image 109 Ergonomic shovel

# Cleaning equipment with colour system

Hygienic down to the last detail.

# Shadow boards

Hygienic and clear.



Image 110



Image 111 Shadow board for wall mounting coloured, 2000 x 1150 mm

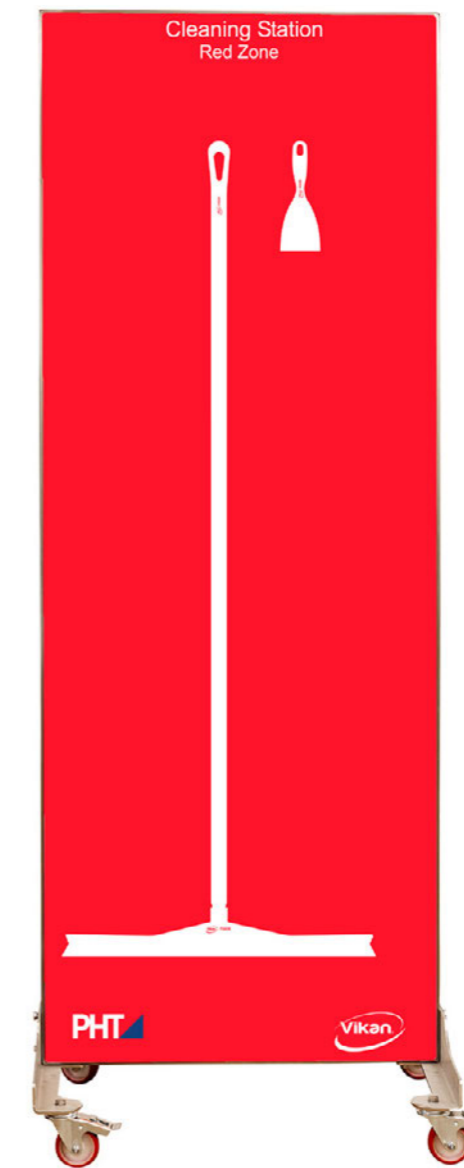

Image 112 Shadow wall with wheels coloured, 2000 x 750 mm



Image 113 Shadow board for wall mounting coloured, 600 x 300 mm

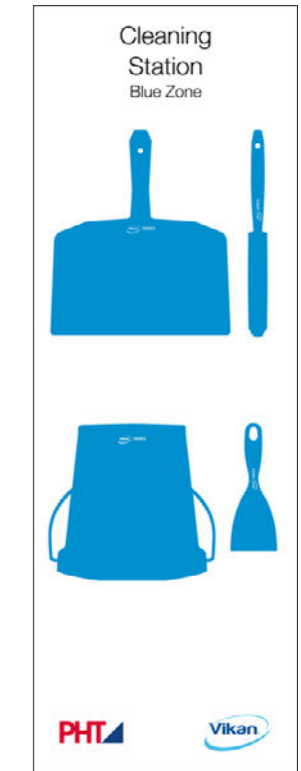

Image 114 Shadow board for wall mounting white, 1200 x 400 mm

# Holistic concepts

from entrance to dispatch.

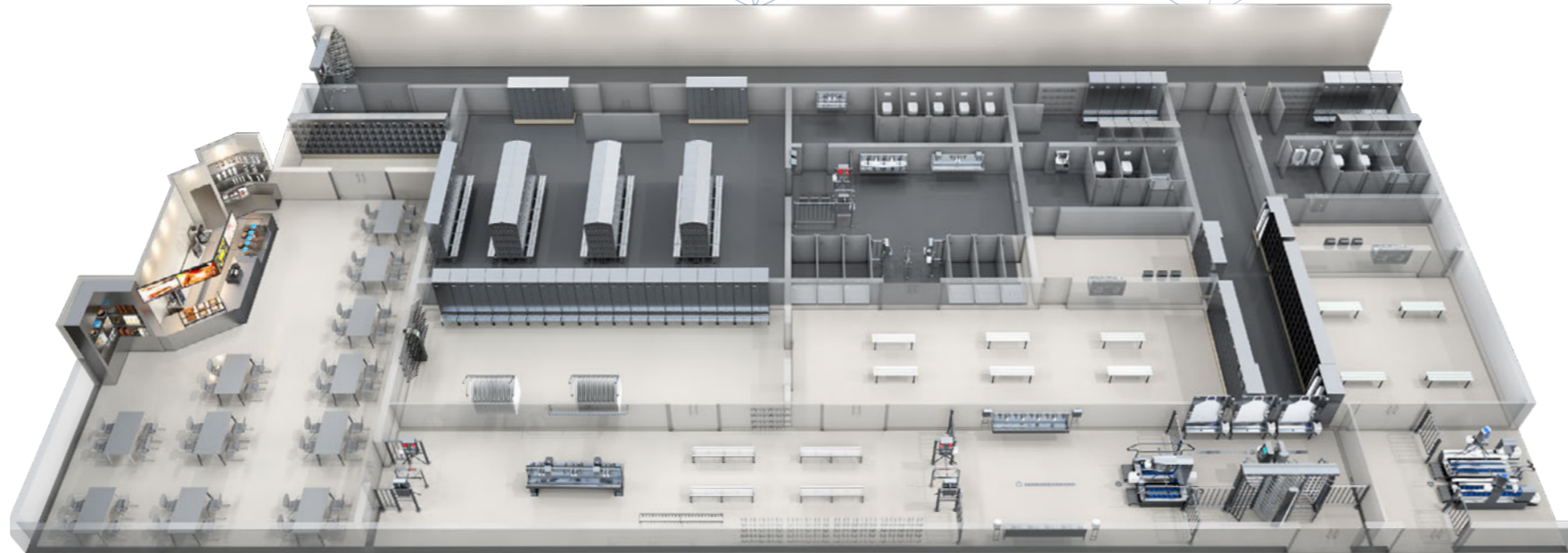

Image 115

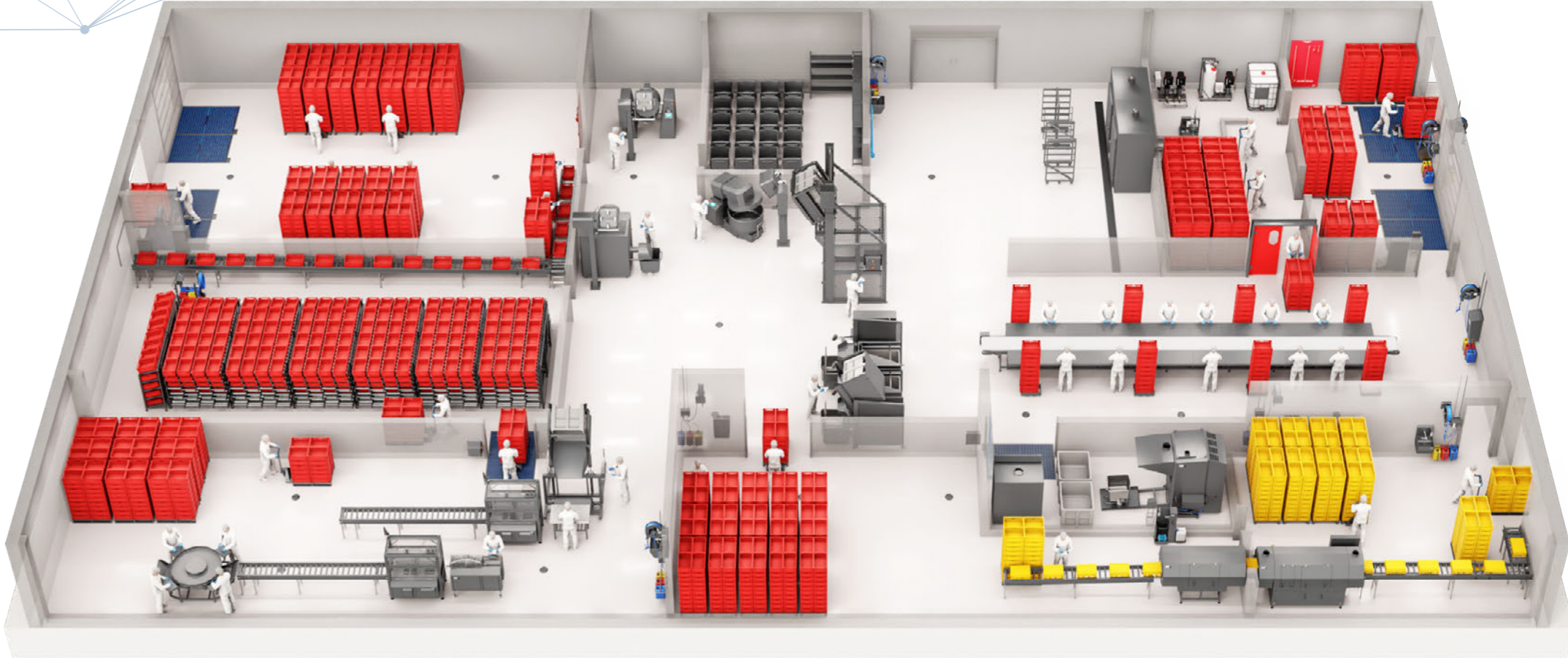

Image 116

# Holistic hygiene solutions

To achieve success, you have to think bigger.

Every business has a unique focus. Our approach is to offer optimal solutions for all aspects of industrial hygiene requirements. Ultimately the success of your business depends on a well-functioning, holistic hygiene solution in which all the individual components work together seamlessly. For that, you need a partner who can provide you not only with products but also with complete solutions.

If you want to work with an active partner who can offer you a well-considered and practical hygiene solution, speak to us.

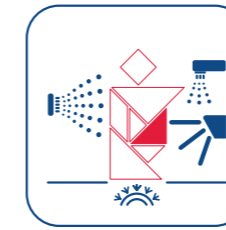

Hygiene equipment

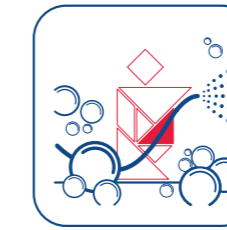

Foam cleaning

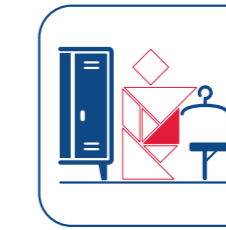

Change room equipment



Cleaning equipment

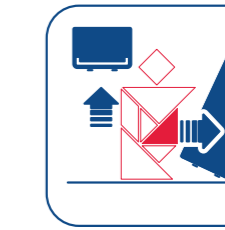

Ergonomics

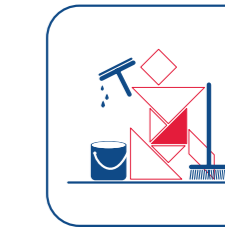

Cleaning brush ware

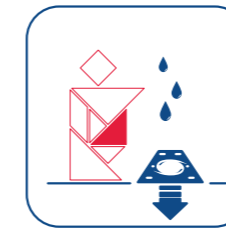

Floor drainage systems

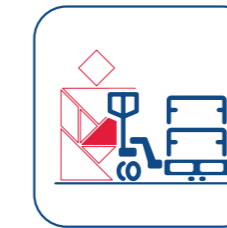

Conveyor and racking systems



Factory equipment



Doors and components

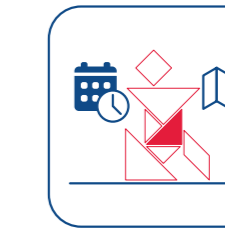

Detail planning

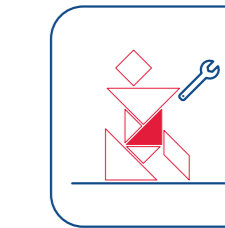

Assembly, commissioning and maintenance

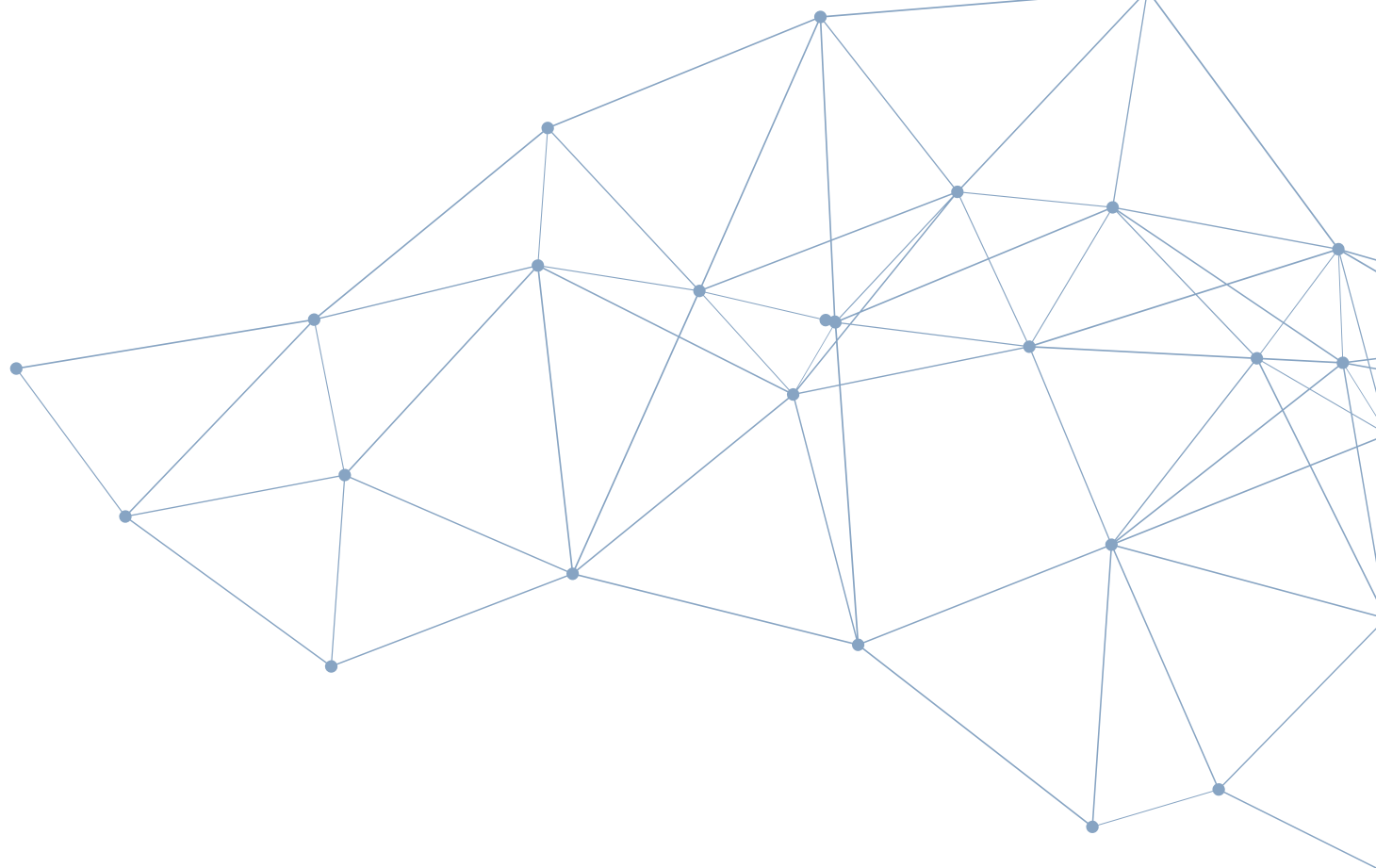

**PHT Southern Germany**

Förchenholzstraße 19  
D-83646 Bad Tölz  
Tel. +49 (0) 80 41-799 24-0  
info.des@pht.group

**PHT Northern Germany**

Auf dem Tigge 33  
D-59269 Beckum  
Tel. +49 (0) 25 21-82 39 78-0  
info.den@pht.group

**PHT Austria**

Grabenweg 68 / Top 7  
A-6020 Innsbruck  
Tel.: +43 512 319 502  
info.at@pht.group

**PHT South Africa**

134 Edison Crescent  
Centurion 0157  
Tel. +27 (0) 861 777993  
info.za@pht.group



[www.pht.group](http://www.pht.group)

