

PHT

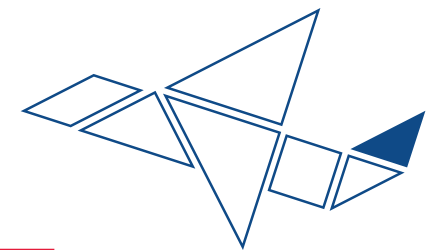

Technology

www.pht.group

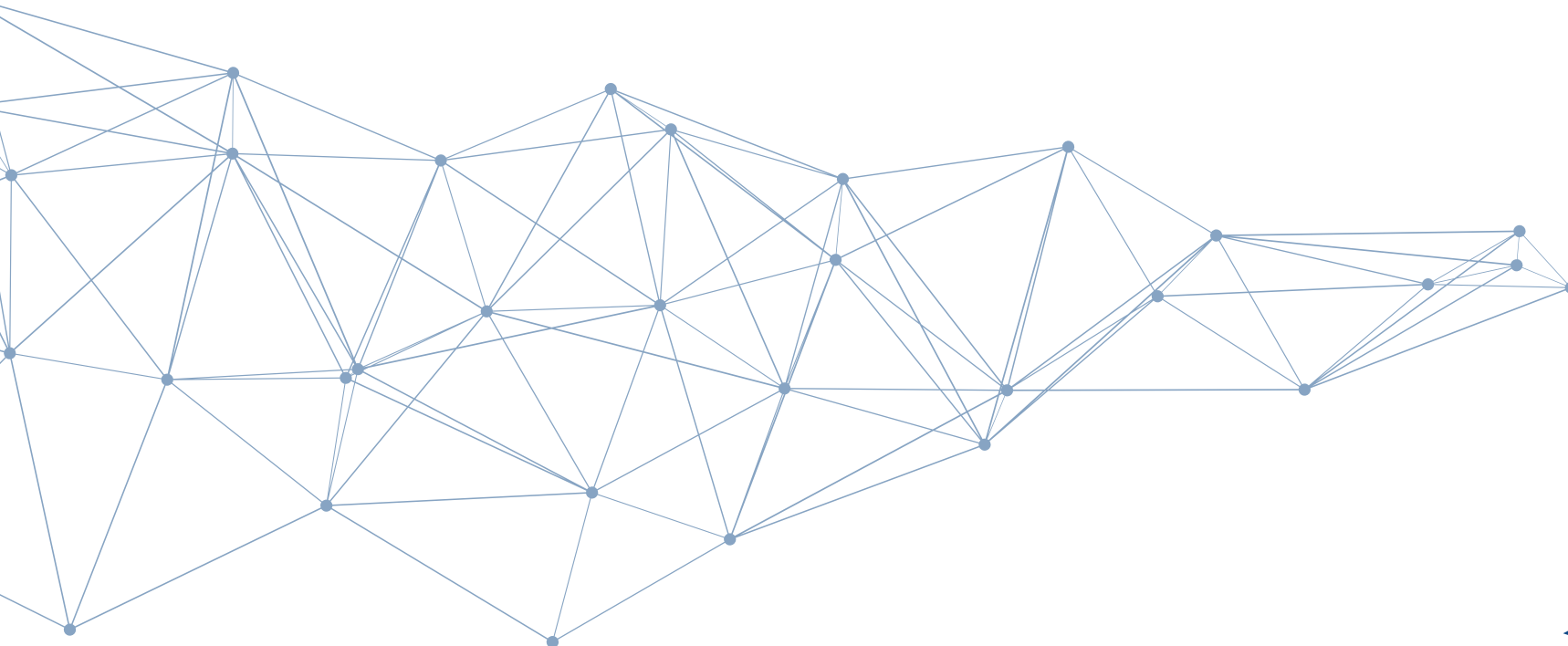

PHT stands for Partnership, Hygiene and Technology

To help you find your way around the PHT world, we have organized our portfolio according to three business units:

Partnership

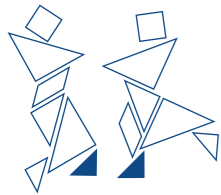

Service

From conceptualization, detailed technical planning to total hygiene packages

After-Sales-Service

From delivery and installation, training and commissioning, as well as start-up, up to maintenance and a service contracts

Hygiene



Employee hygiene

We cover all hygiene-relevant points in your workflow starting with access control, from change rooms and canteens to hygiene lobbies and all necessary hygiene equipment for your facility.

Facility hygiene

Everything you need for cleaning your facility and machines: from high-quality brush ware to low-pressure foam cleaning technology, coupled with all the required accessories for drainage systems, and complete furnishing of your chemicals room.

Technology

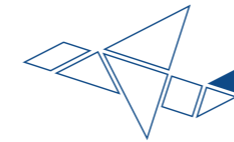

Cleaning and drainage technology

We offer innovative cleaning and drying technology for all tubs, containers, trolleys and transfer systems in your facility. And because thinking about hygiene does not end at the wastewater outlet of a machine, we also offer appropriate drainage technology.

Handling and logistics systems

From the design and installation of high-quality, hygienic stainless steel equipment to automated lifting and tilting systems and technology for conveyor, racking and commissioning systems. Modern systems protect your products and reduce the time spent on the production floor, and so promote hygiene.

We further design customized hygienic slaughtering, deboning and cutting as well as smoking and cooking systems. Modern systems, for example UV and Microwave technology, protect your products, shorten the time required for manual input and thereby increase the overall hygiene.



PHT Products of Technology

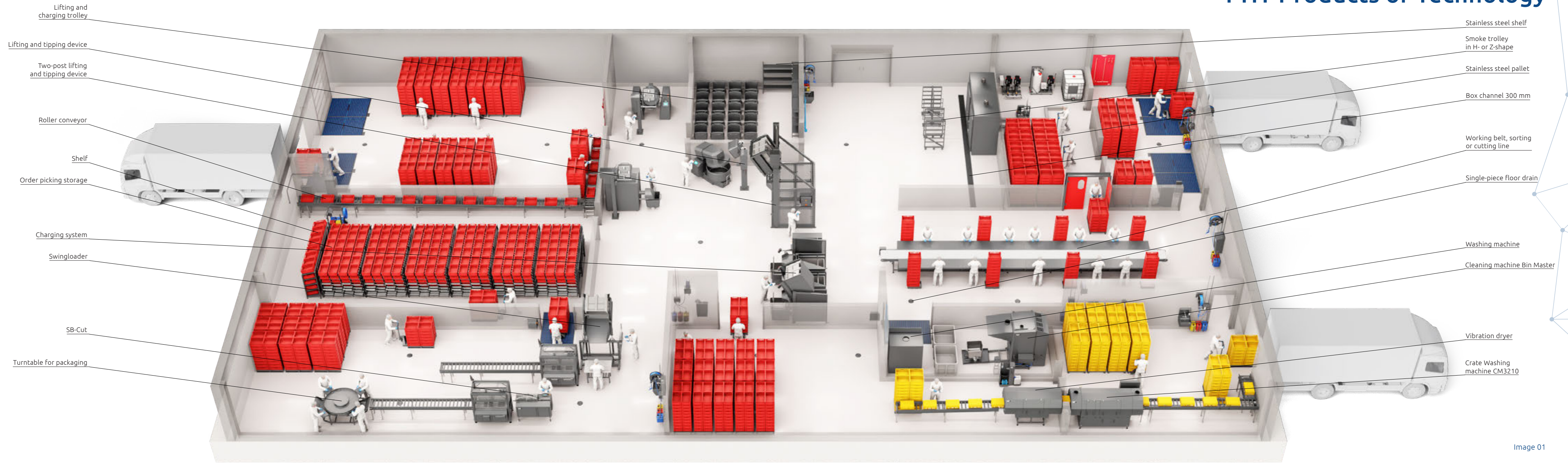

- Lifting and charging trolley
- Lifting and tipping device
- Two-post lifting and tipping device
- Roller conveyor
- Shelf
- Order picking storage
- Charging system
- Swingloader
- SB-Cut
- Turntable for packaging

- Stainless steel shelf
- Smoke trolley in H- or Z-shape
- Stainless steel pallet
- Box channel 300 mm
- Working belt, sorting or cutting line
- Single-piece floor drain
- Washing machine
- Cleaning machine Bin Master
- Vibration dryer
- Crate Washing machine CM3210

Leading through innovation

Modern technologies for hygiene-sensitive areas.

Food manufacturers and companies with hygiene-sensitive areas have a particular special responsibility for hygienic and safe processes. PHT offers modern technologies that optimise the workflow and ensure hygiene. This begins with innovative cleaning systems for containers and extends to professional floor drainage.

Modern conveying technology, ergonomic systems and well thought-out operating equipment make work processes efficient and protect your products.

Innovative Technology for your production

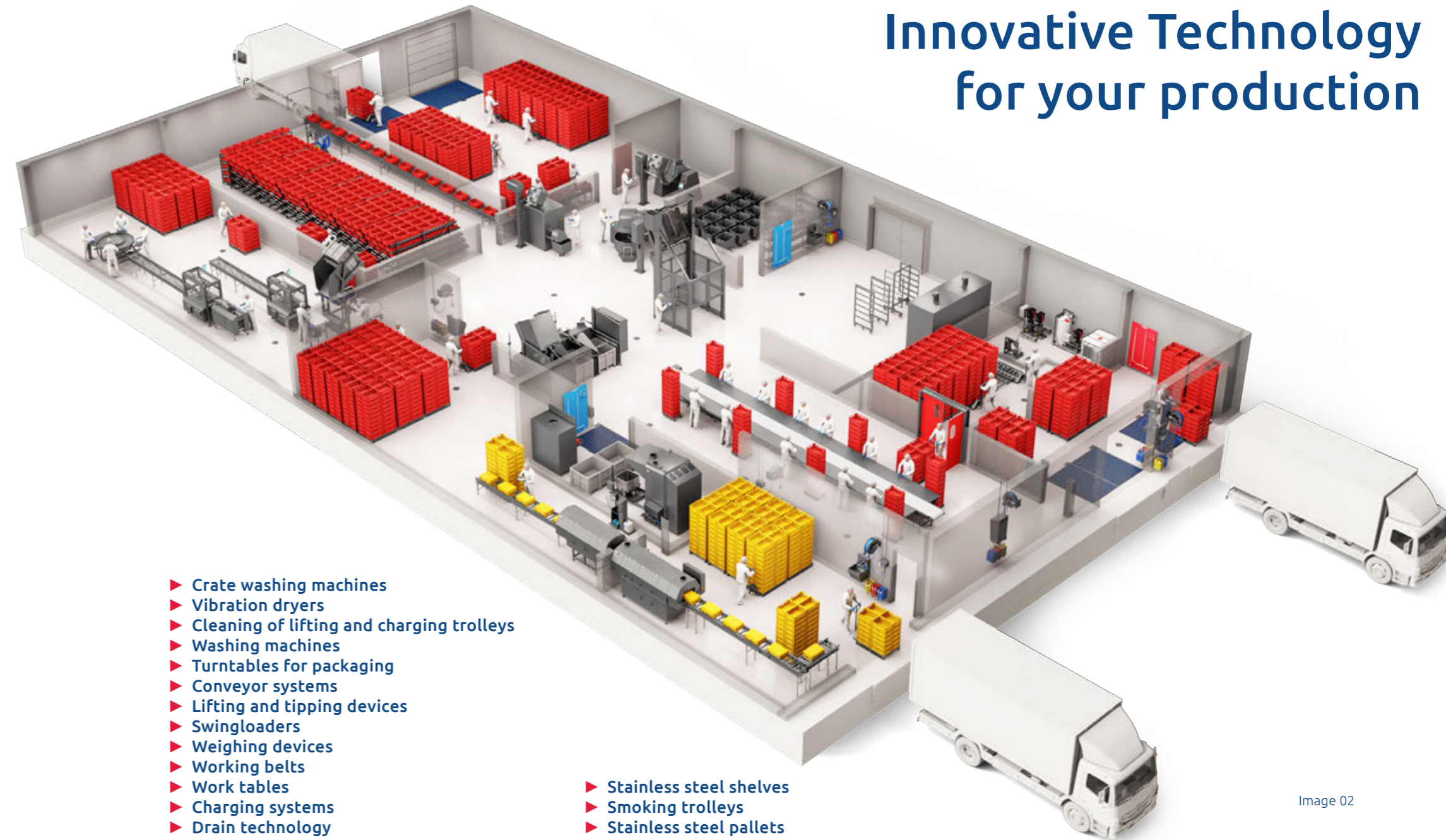

- ▶ Crate washing machines
- ▶ Vibration dryers
- ▶ Cleaning of lifting and charging trolleys
- ▶ Washing machines
- ▶ Turntables for packaging
- ▶ Conveyor systems
- ▶ Lifting and tipping devices
- ▶ Swingloaders
- ▶ Weighing devices
- ▶ Working belts
- ▶ Charging systems
- ▶ Drain technology

- ▶ Stainless steel shelves
- ▶ Smoking trolleys
- ▶ Stainless steel pallets

Image 02

Image 03



CM Crate washing machine

Cleaning of E-boxes.



Image 04 Crate washing machine CM3210



Image 05 Vibration dryer



Image 06 Crate washing machine CM3210 with air dryer

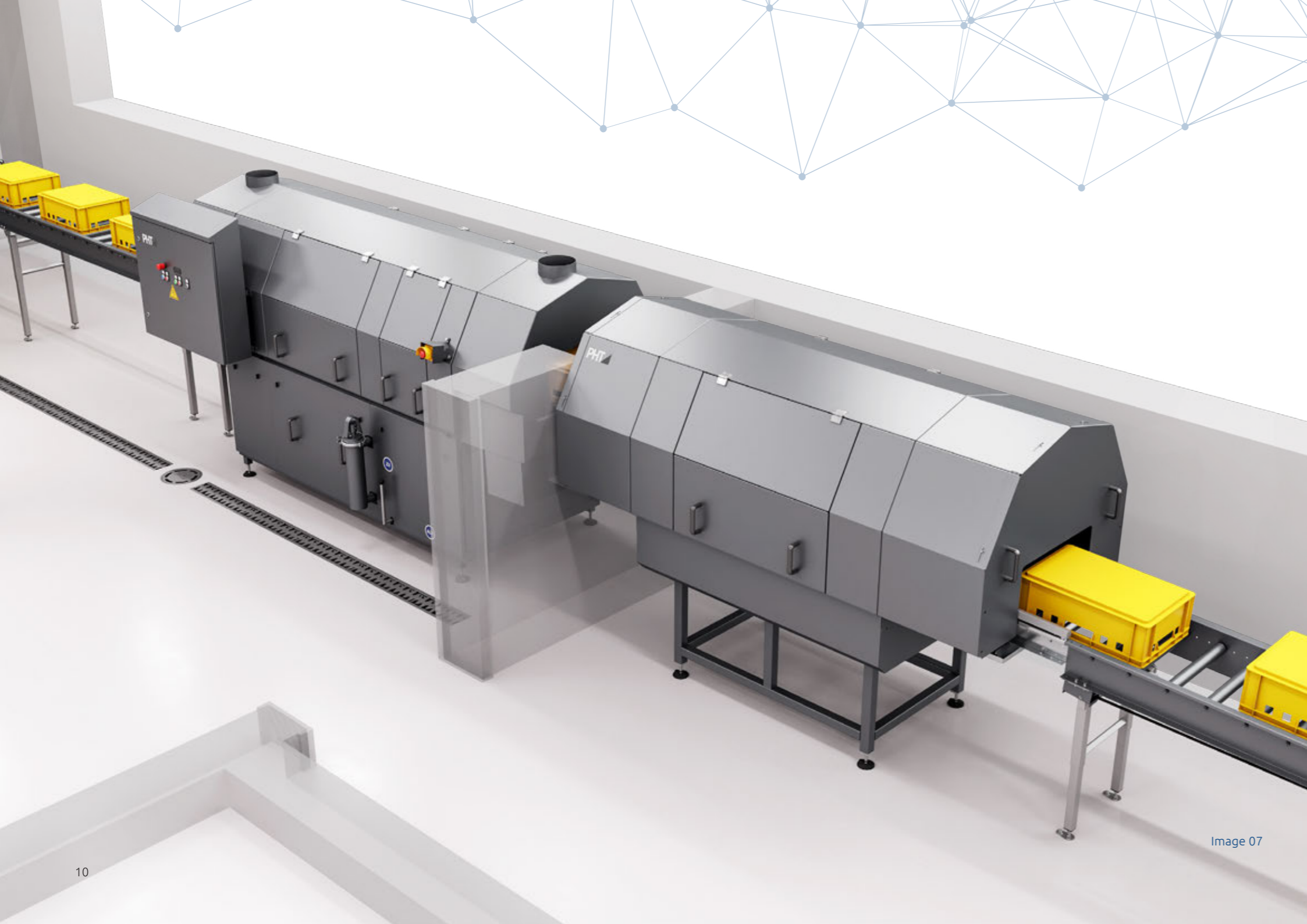

Image 07

Vibration dryer

Hygienic container drying rethought.



Image 08 Vibration dryer, opened



Image 09 Vibration dryer, closed



Image 10 Vibration dryer, side view

2-phase-door opening

CM Crate washing machine

Individual for many conditions.



Image 11 Cleaning position



Image 12 Drying position



Image 13 Ready for use



Image 14 Crate washing machine CM-series type 5820



Image 15 Crate washing machine CM-series type 7820 with coarse pre-rinsing and steam disinfection

Unbeatable details



Image 16 Rotating nozzles - efficient cleaning



Image 20 Large openings - optimum accessibility



Image 24 2-phase door opening - cleaning position



Image 17 Inclined / offset container guidance - no splash shadows



Image 21 No hold-downs - simple operation



Image 25 2-phase door opening - drying position



Image 18 Pressure gauge for pressure testing - simple function check

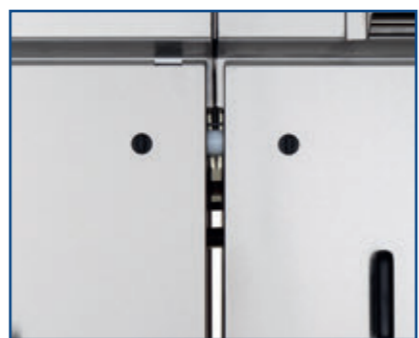

Image 22 Connection with distance - optimal hygiene



Image 26 Removable piping - optimum accessibility



Image 19 Ideal cleaning of the level sensors - durable and functionally reliable

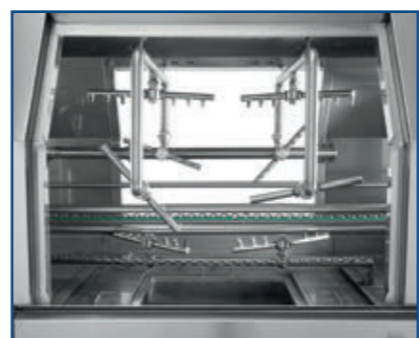

Image 23 Optimal zone length - little water/chemical carry-over

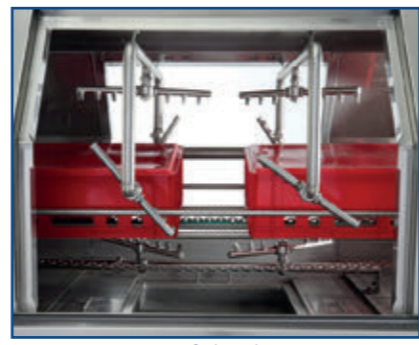

Image 27 Rotors of the cleaning zone

CM Crate washing machine

Optionally with drum filter.



Image 28 Crate washing machine CM-series with drum filter, opened



Image 29 Crate washing machine CM-series with drum filter

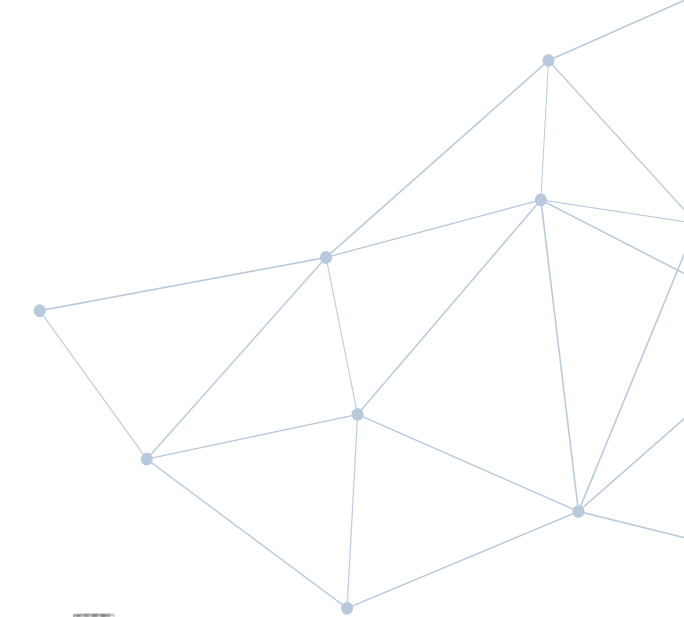



Image 30

Cleaning machine Bin Master

Large containers easily cleaned.



Image 31 Bin Master, ready for use



Image 32 Bin Master, technic



Image 33 Bin Master, opened



Image 34

Washing machine

Cleaning of equipment.



Image 35 Cleaning machine HPW 40BT, 720 mm width



Image 36 Cleaning machine HPW 60BT, 836 mm width



Image 37 Cleaning machine HPW 80BT, 996 mm width



Image 38 Cleaning machine HPW 130BT, 1506 mm width



Image 39 HPW 40BT - HPW 80BT inside view



Image 40 HPW 130BT inside view

Conveyor technology

Suitable for your requirements.

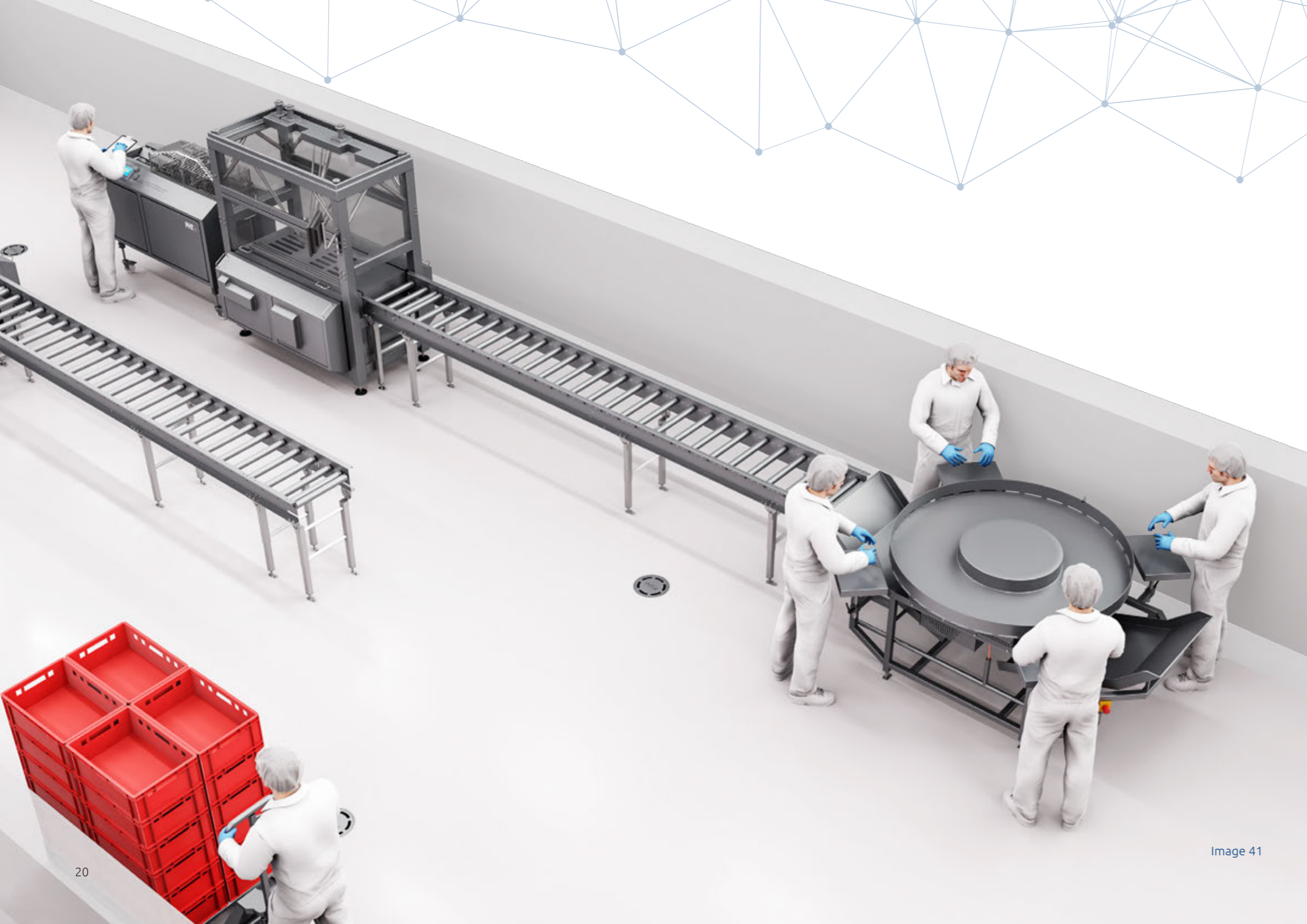

Image 41



Image 42 Turntable for packaging

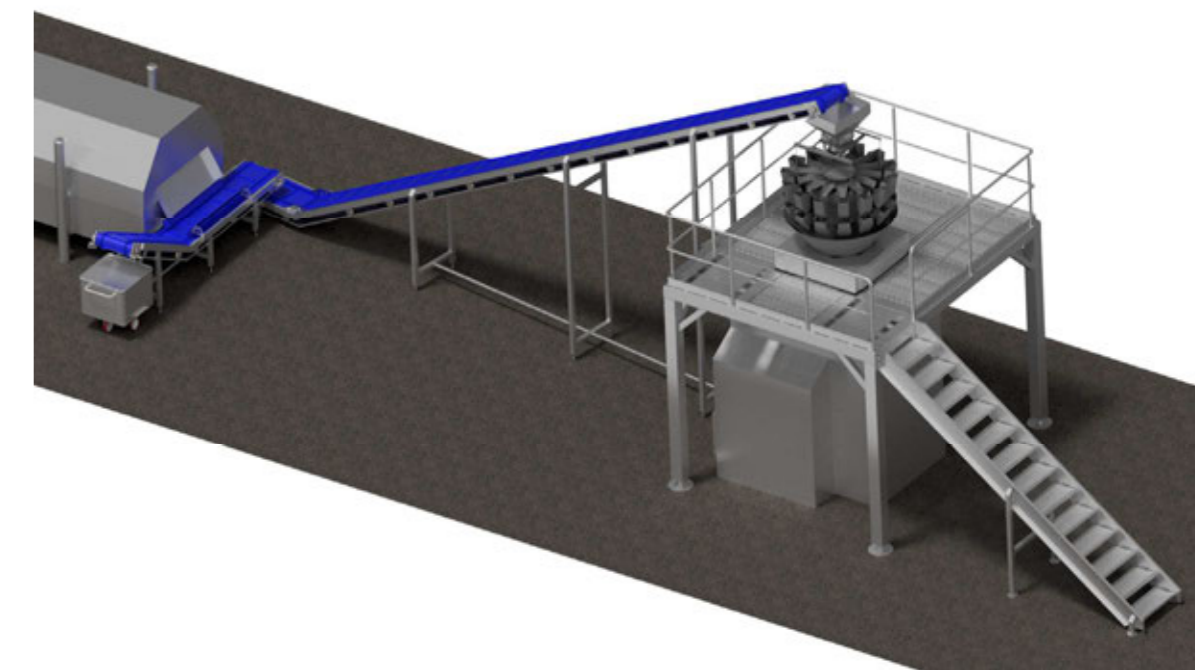

Image 43 Conveyor with platform

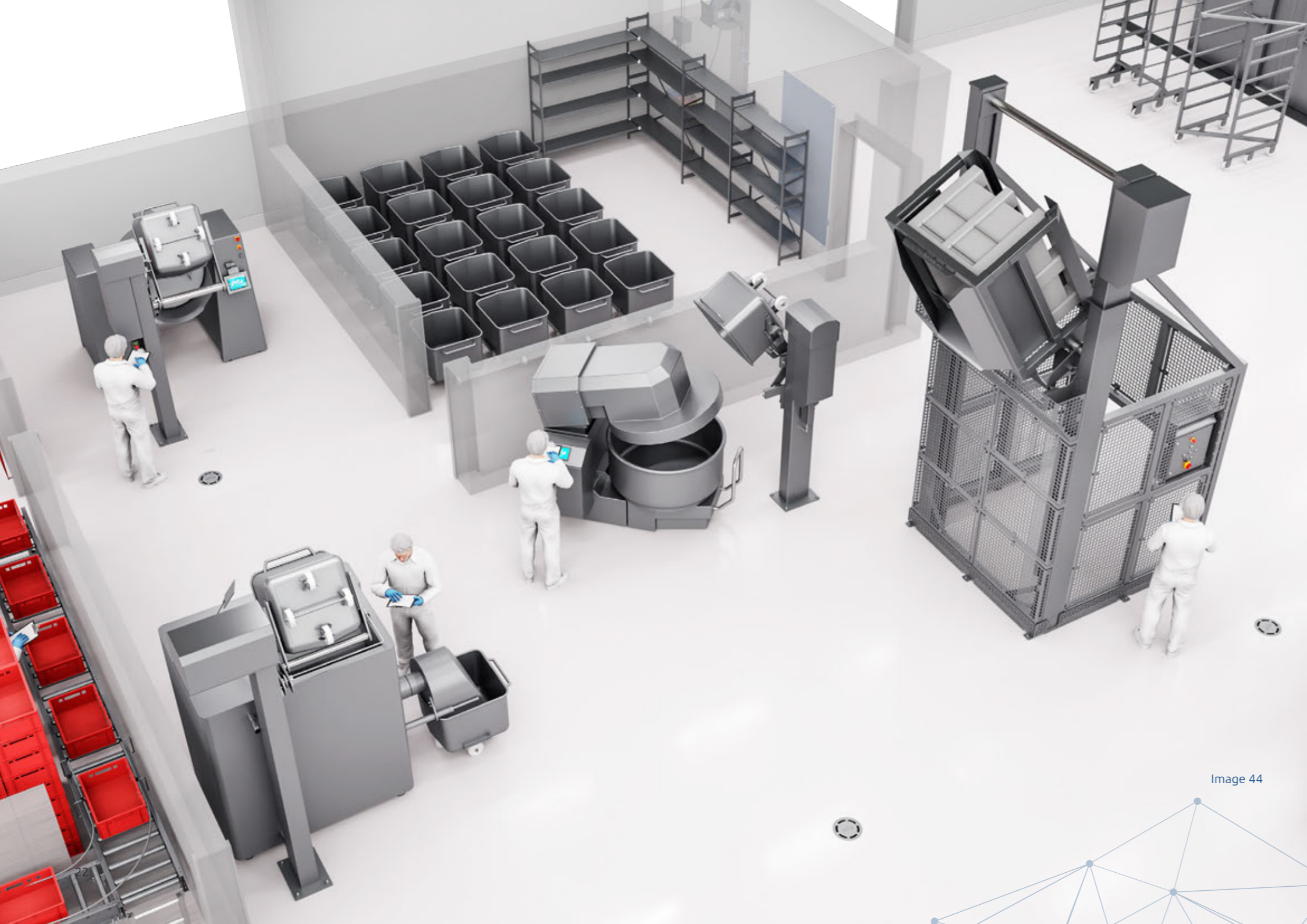

Image 44

Lifting and tipping

Ergonomic solutions.



Image 45 Lifting and tipping device



Image 46 Two-post lifting and tipping device



Image 47 Weighing device WVp-9797-350



Image 48 Lifting device HVp-9797-350

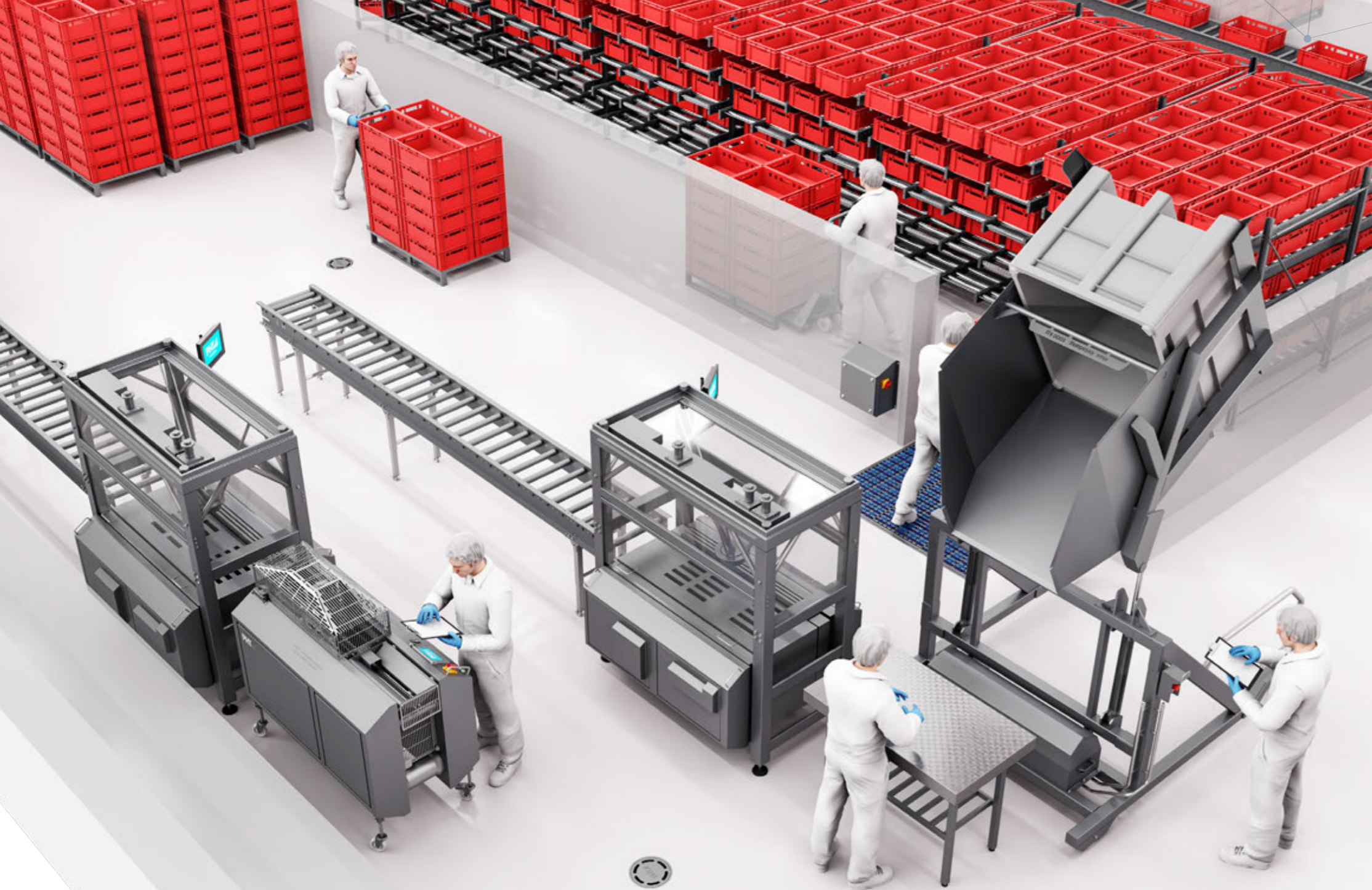

Image 49

Swingloader

Ergonomic carriage.



Image 50 Swingloader-1000



Image 51 Swingloader-R-1000



Image 52

Working belts and systems

Efficient handling.



Image 53 Working belt, sorting or cutting line

Image 54 Work and / or sorting table with standing platform

Image 55 Charging system 800

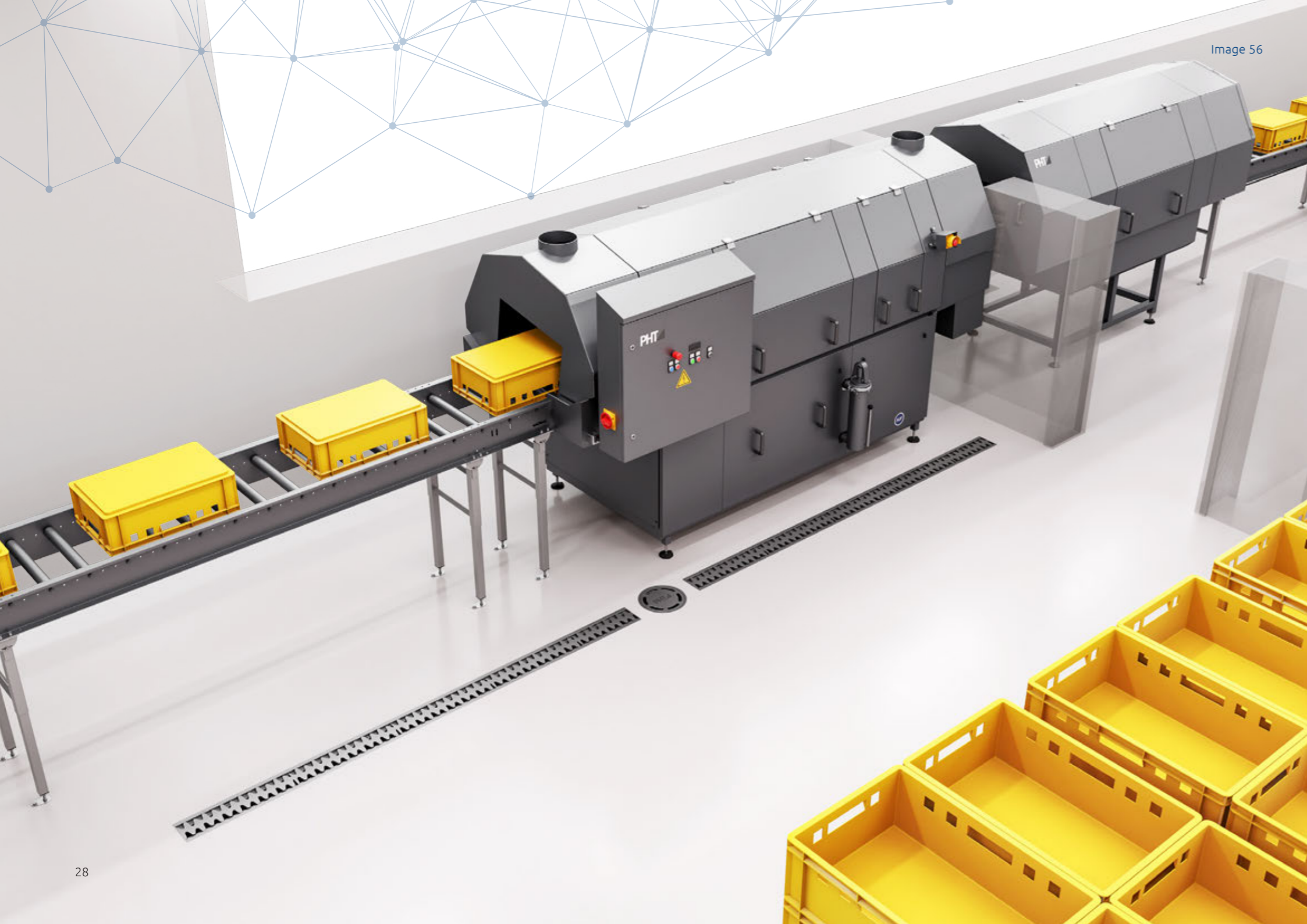

Image 56

Drainage technology

Safe and reliable.



Image 57 Vertical floor drain with box channel 150 mm

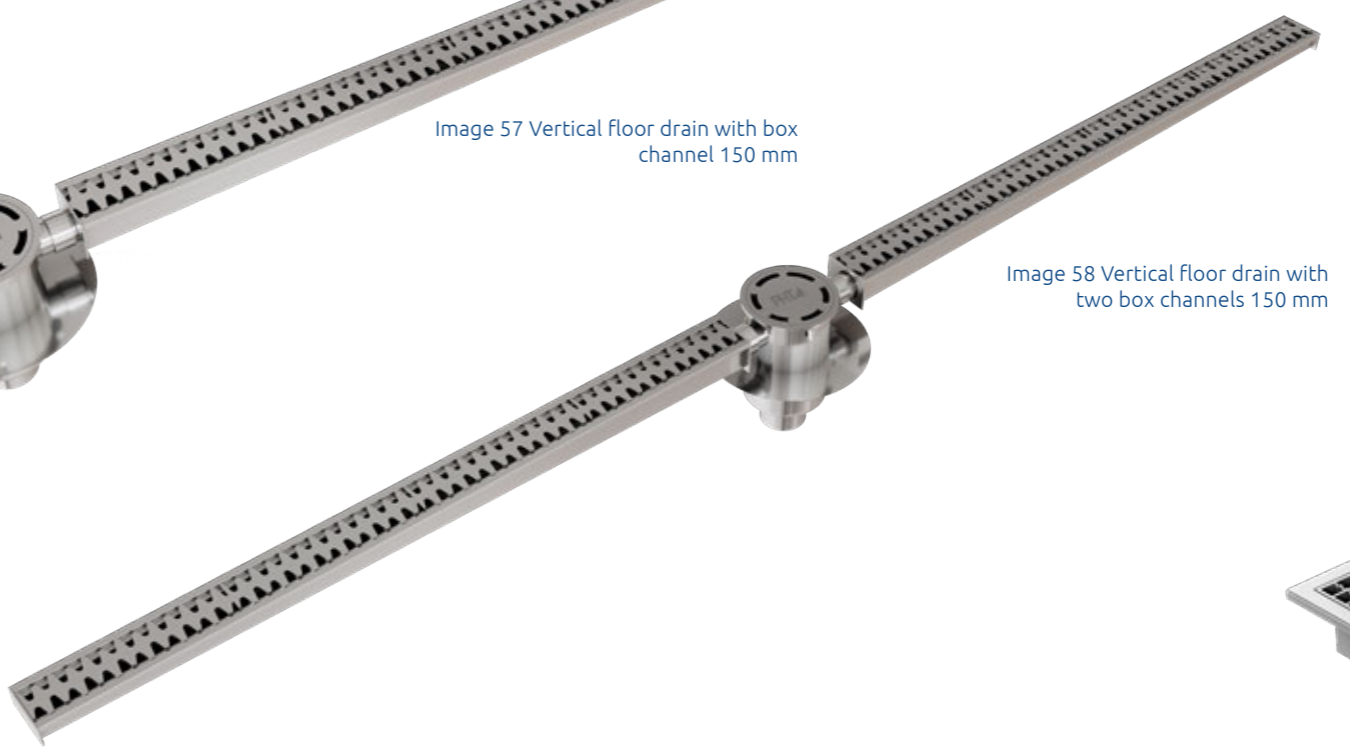

Image 58 Vertical floor drain with two box channels 150 mm



Image 61 Box channel 300 mm



Image 59 Vertical single-piece floor drain



Image 60 Vertical two-piece floor drain

Factory equipment

Furnishing in hygienic design.



Image 62 Wall cabinet



Image 63 Material cabinet



Image 64 Stainless steel shelving systems



Image 65 Sink unit with basin



Image 66 Sink unit with basin and storage rack



Image 67 Sink unit



Image 68 Packing table



Image 69 Plant table with shelf



Image 70 Plantic open

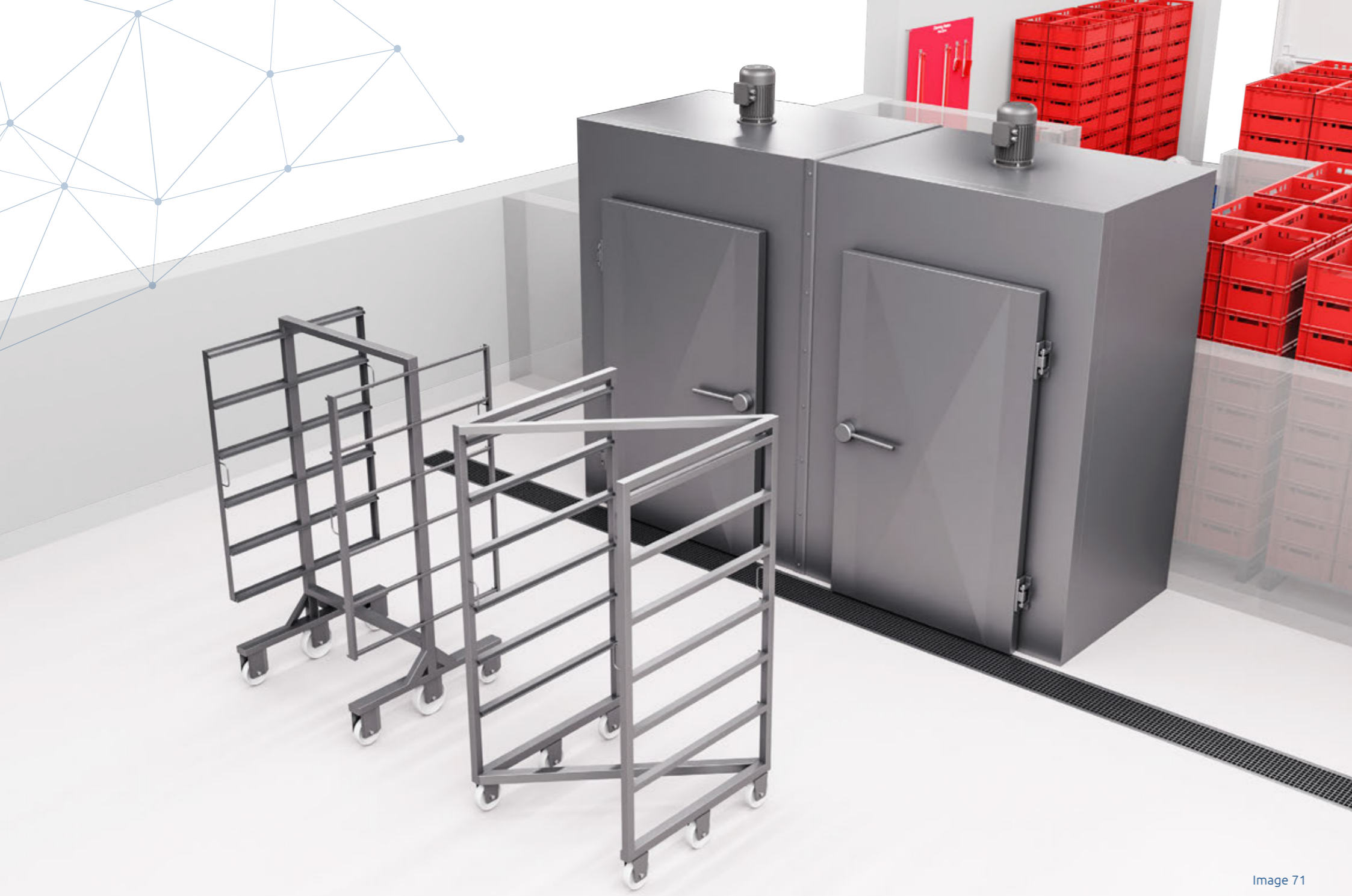

Image 71

Smoke and charging trolley

Safe processes for your production.



Image 72 Smoke trolley in H-shape



Image 73 Lifting and charging trolley



Image 74 Smoke trolley in Z-shape



Image 75

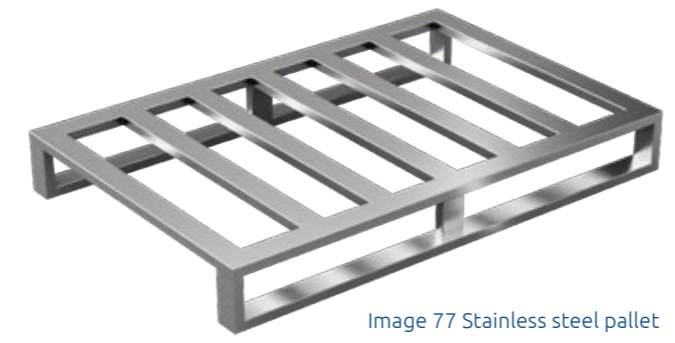

Image 77 Stainless steel pallet



Image 76 Swing door

Doors and pallets

Hygienic and robust.



Image 78 Swing door with two leaves with or without ram protection

Holistic concepts

from entrance to dispatch.

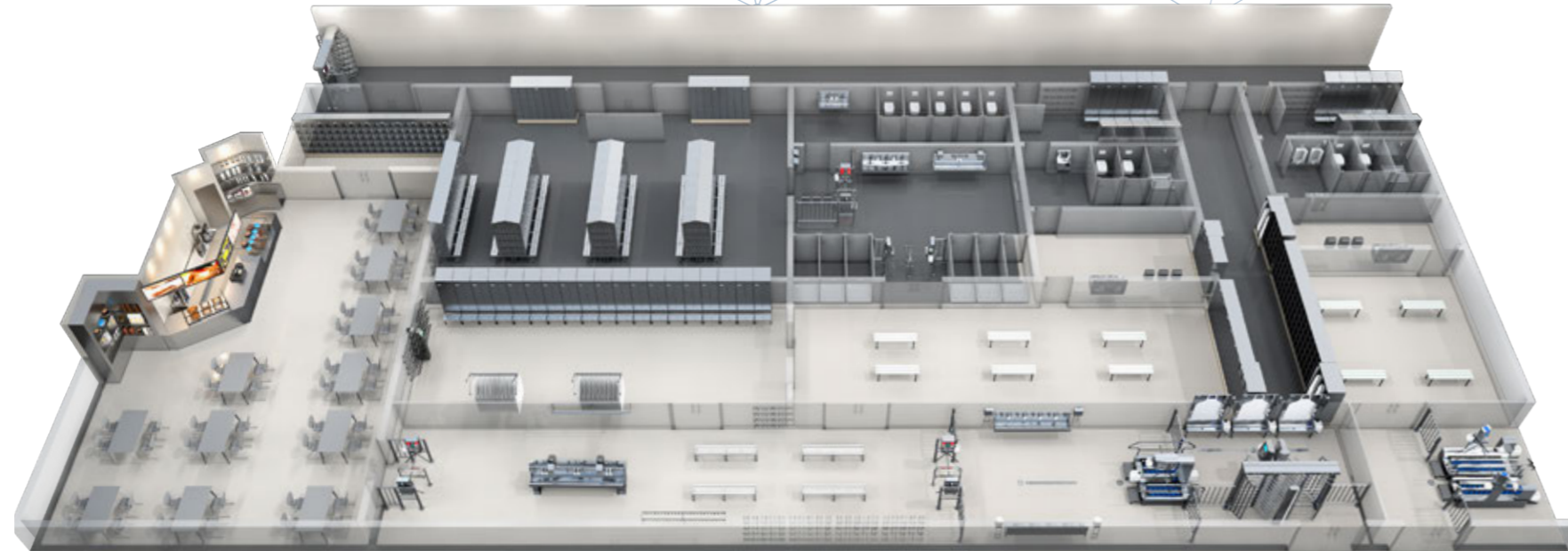

Image 79

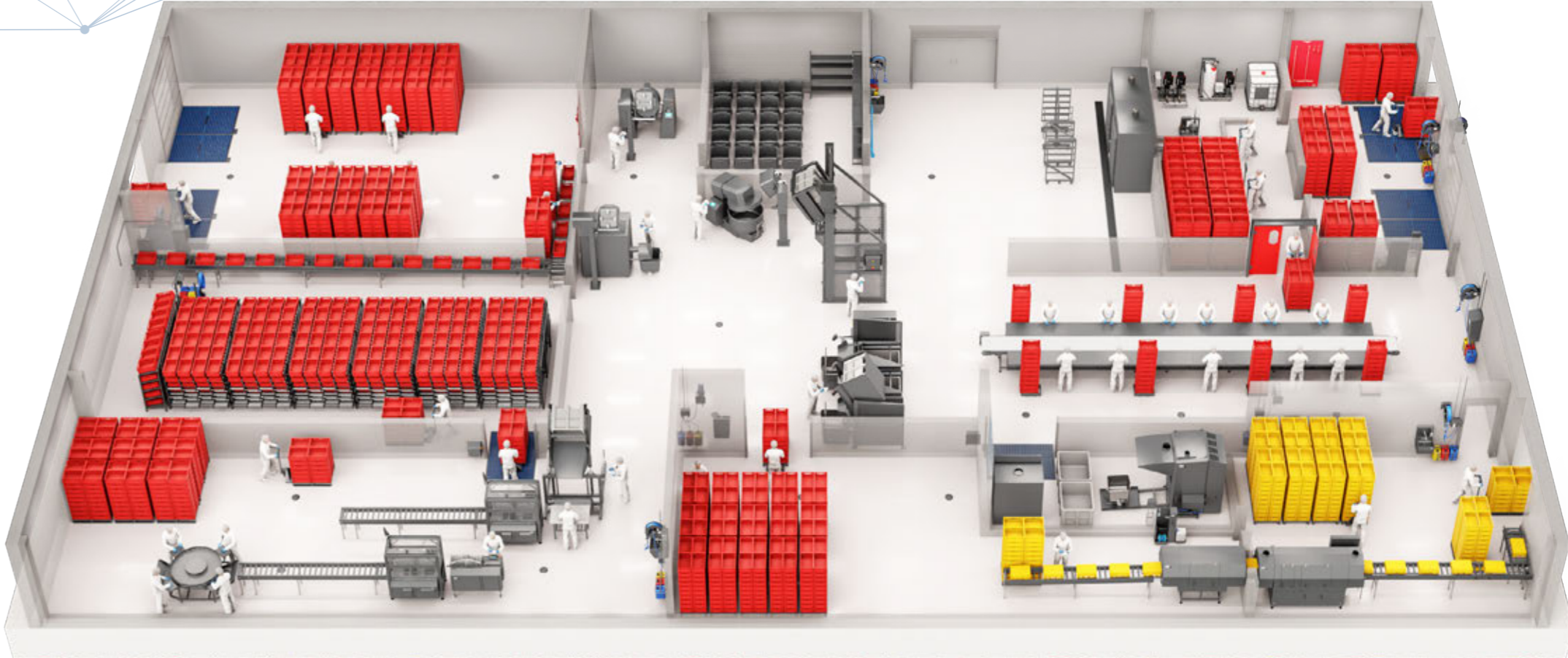

Image 80

Innovative technology

More efficient in daily production.

For the success of companies with hygiene-sensitive areas, it is crucial that all areas complement each other and function as a whole. This protects employees and hygienically safeguards products in your company. Efficient crate cleaning systems, conveyor technology tailored to your company, ergonomics and the right operating equipment facilitate the workflow and complete your overall concept, in which personnel and operating hygiene as well as technology interlock.

Would you like to have a partner at your side who both develops the right concept for you and provides fast service afterwards? Get in touch with us.

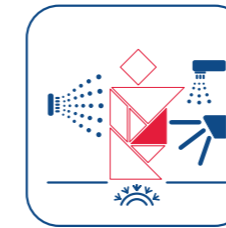

Hygiene equipment

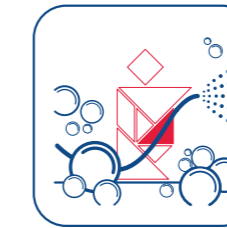

Foam cleaning

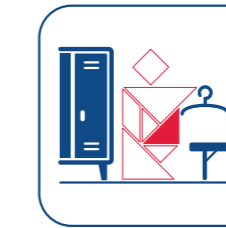

Change room equipment



Cleaning equipment

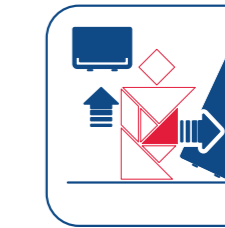

Ergonomics

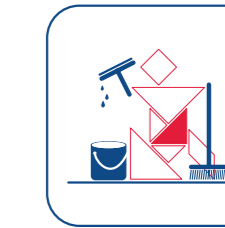

Cleaning brush ware

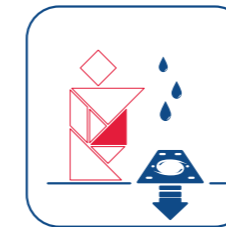

Floor drainage systems

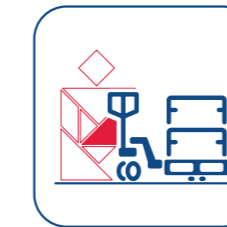

Conveyor and racking systems



Factory equipment



Doors and components

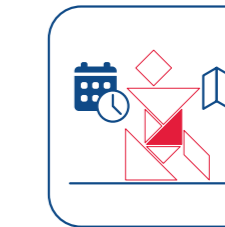

Detail planning

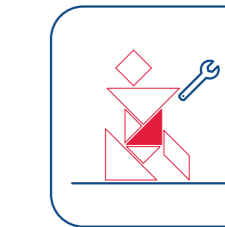

Assembly, commissioning and maintenance

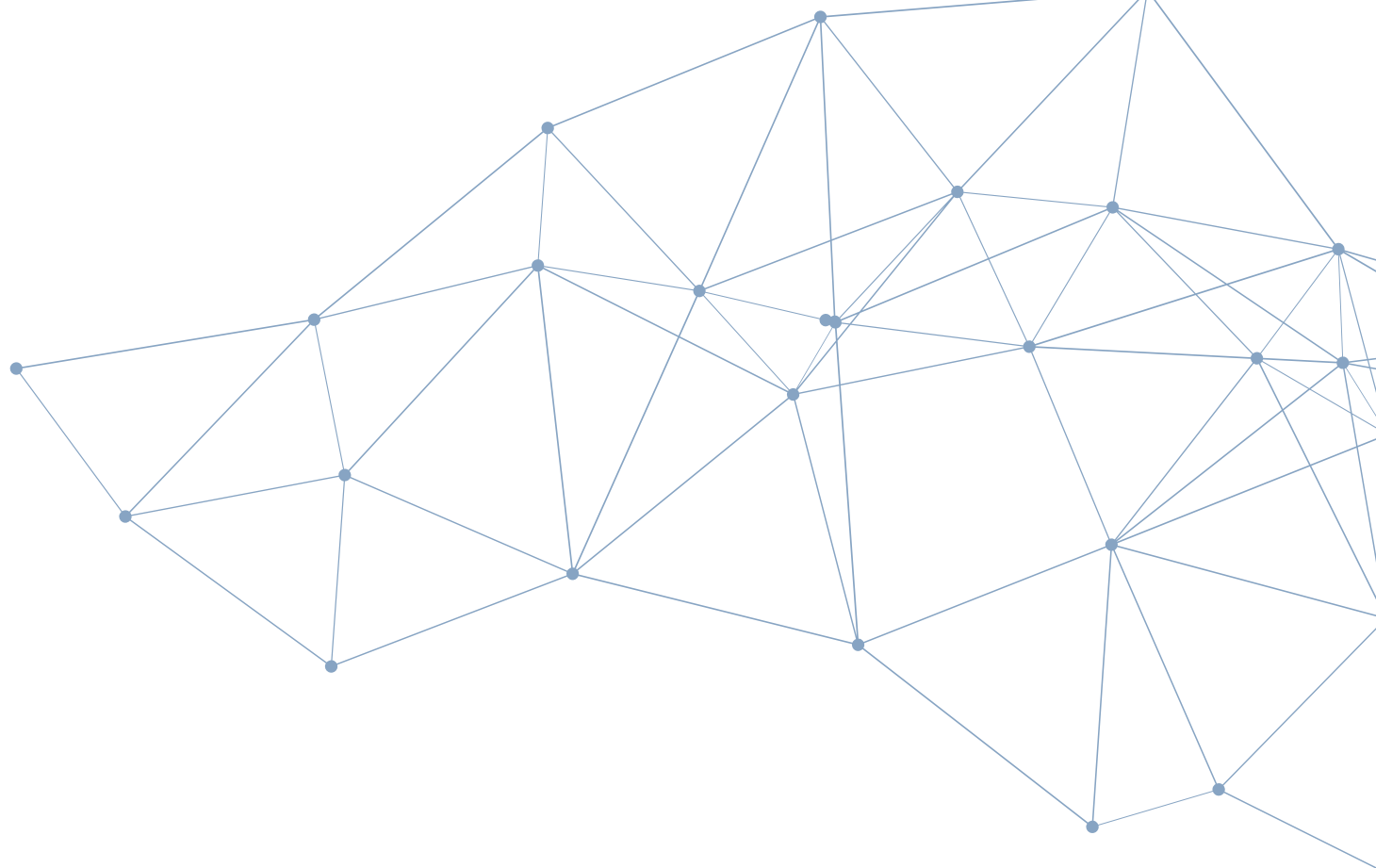

PHT Southern Germany

Förchenholzstraße 19
D-83646 Bad Tölz
Tel. +49 (0) 80 41-799 24-0
info.des@pht.group

PHT Northern Germany

Auf dem Tigge 33
D-59269 Beckum
Tel. +49 (0) 25 21-82 39 78-0
info.den@pht.group

PHT Austria

Grabenweg 68 / Top 7
A-6020 Innsbruck
Tel.: +43 512 319 502
info.at@pht.group

PHT South Africa

134 Edison Crescent
Centurion 0157
Tel. +27 (0) 861 777993
info.za@pht.group



www.pht.group

